

# The HSRP Monitoring and Evaluation System

by Jurrien Toonen

MOHP-HSRP-M&E Unit

Introduction workshop

10-15 May 2003

# The Health Reform

## Objectives:

1. **Universal coverage**
2. **Improved service delivery**
3. **Improved organisation and management**
4. **A reform of the pharmaceutical sector**

# Two types of reform

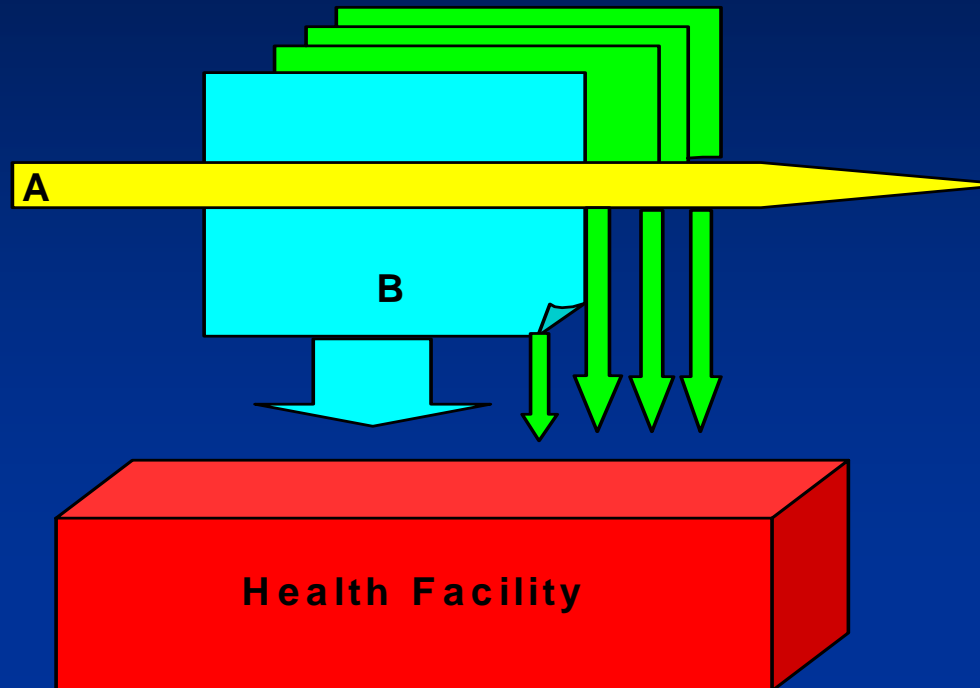

Phasing (!?)

# Five guiding principles

1. Universal coverage
2. Quality
3. Equity
4. Efficiency
5. Sustainability

# Six strategies

- A. Institutional development
- B. Infrastructure Development
- C. Human resource development
- D. Services reform
- E. Financing reform
- F. Pharmaceutical reform

# Effect of HSR P

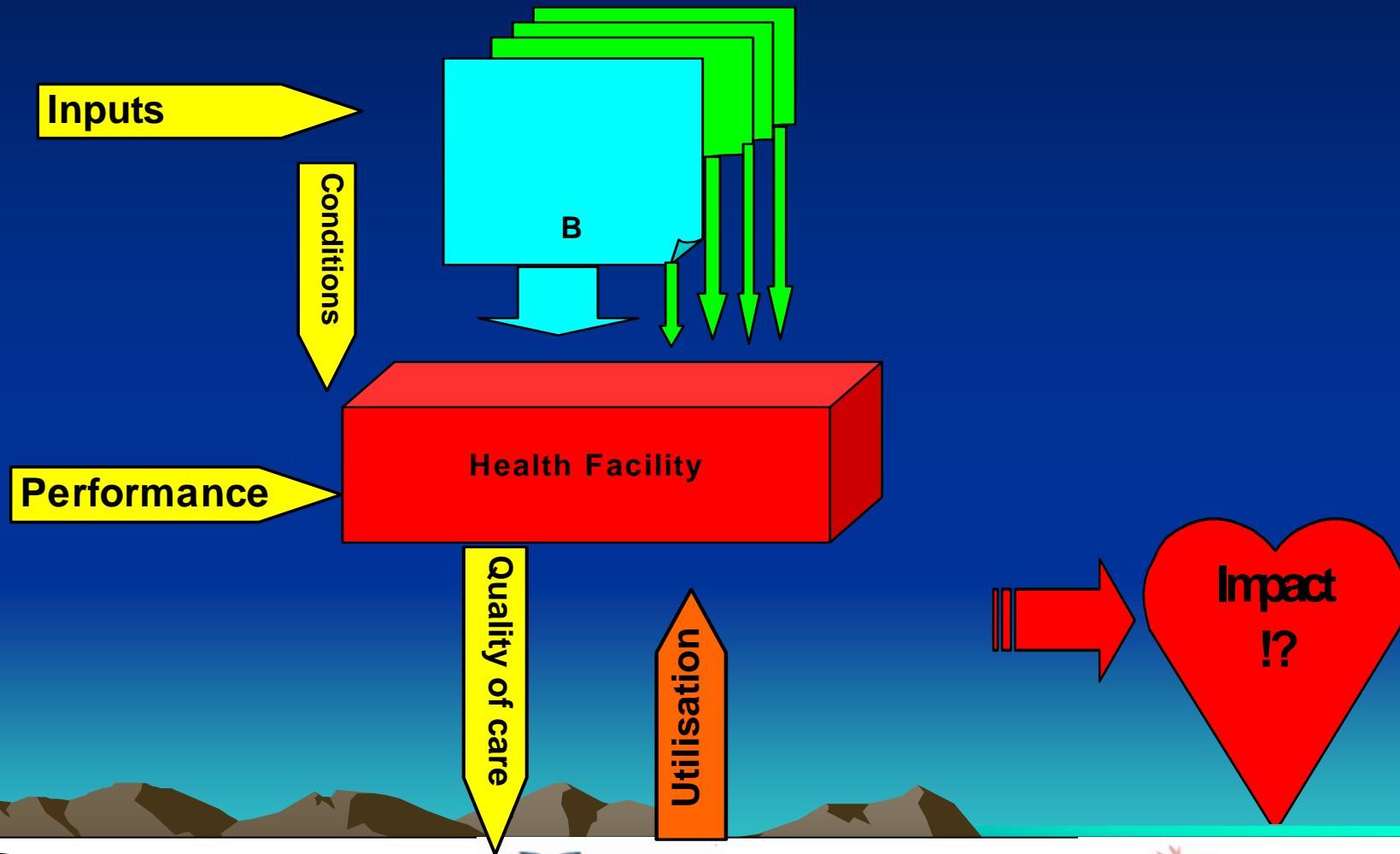

# HSR: specific features

- HIO-reorganisation
- Family Health
- Public Health
- Quality of services
- Right-sizing, right skills-mix

# Systems approach: elements and its relations

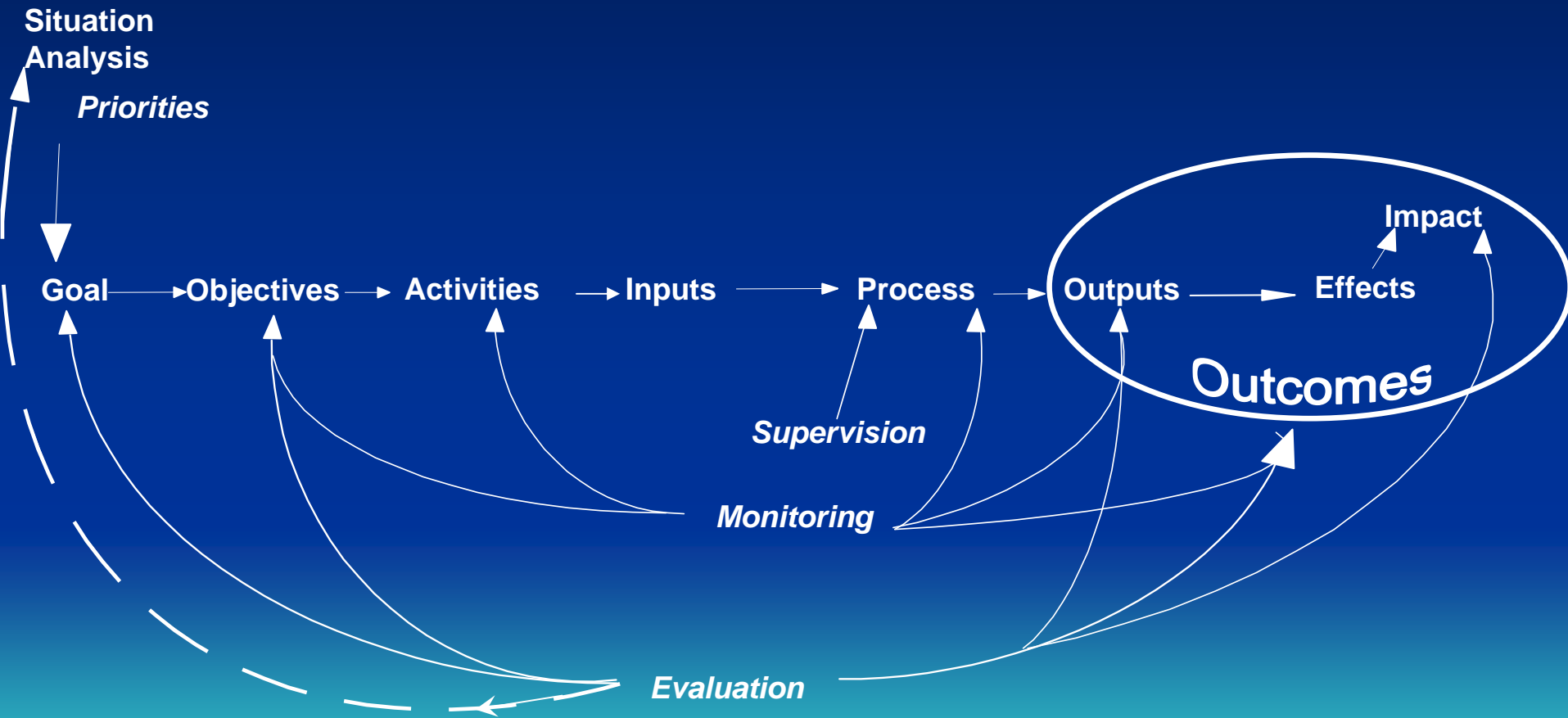

# Types of indicators

- Input (3x)
  - Process
  - Output
  - Effect – Performance
  - Impact
- } Outcomes

# The M&E system

## Principles:

- Reform = process of change
- Validity & accuracy
- Integrated system M *and* E
- Routine information: 2 packages of info

# Criteria Routine Information

- *should assess the health reform*
- *Simple, clear and feasible (SMART)*
- *minimal package of info*
- *For evidence-based decision-making*
- *pace, the effects and the direction*
- *Impact?!*

# Data production & utilisation

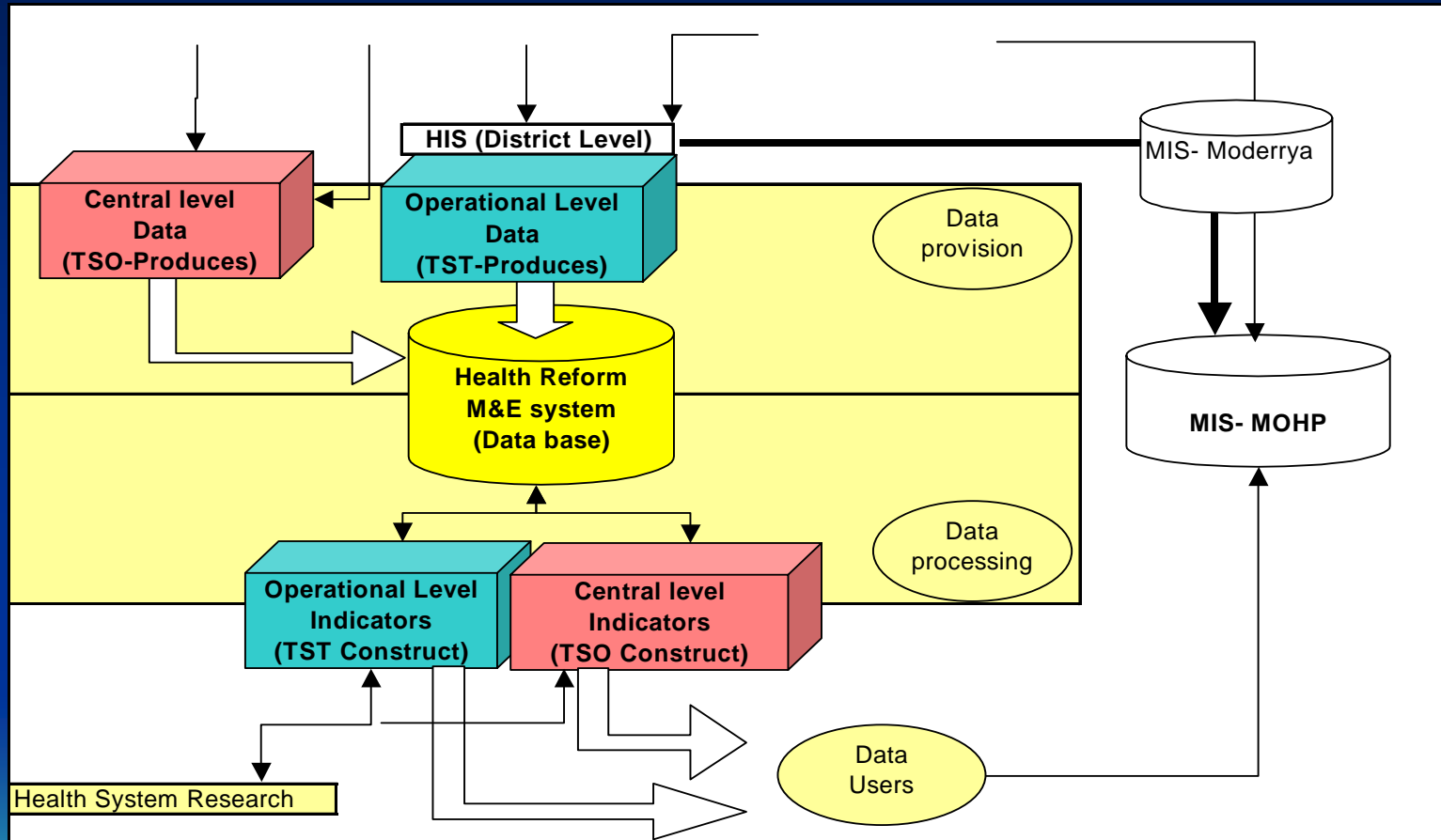

# Monitoring routine information

- Two packages of info
- Software package
- Same structure: producer & user
- 2 Lists of indicators
- Reference manual

# Evaluation

- Regular evaluation (mid-term,.....)
- Health System Research
  - Population based,
  - Facility-based studies
  - costing studies
- Assessment (facility, staff)